

AIR AND VACUUM VALVES

K-01 SERIES

DESCRIPTION

The K-01 Series Air and Vacuum Valve discharges air during the filling or charging of the system and admits air into the system during system drainage, valve or pump shut-off or at water column separation.

MAIN FEATURES

- Reliable operation, reduces water hammer incidents.
- Lightweight, small dimensions, simple and reliable construction.
- Special orifice seat design: combination of a stainless steel seat and an E.P.D.M. or Viton seal assures long-term maintenance-free operation.

PRODUCT SELECTION

- Available in 2", 3", 4", and 6".
- The Air and Vacuum Valve is also available as a Combination Air Valve which includes the addition of a continuous acting Air Release Valve.
- These valves are manufactured with flanged ends to meet any required standard. The 2" valve is also available with NPT male threads.



Air and Vacuum Valve
K-01



Air and Vacuum Valve
K-01STST

SPECIFICATIONS

- Working pressure range:
K-010: 3 - 250 psi
K-010 STST: 3 - 275 psi
K-014 and K-014 STST: 3 - 580 psi
- Testing pressure: 1.5x max working pressure
- Maximum working temperature: 140° F
- Maximum intermittent temperature: 194° F
- Valve coating: Fusion-bonded epoxy in accordance with standard DIN 30677-2, stainless steel optional.

K-01 SERIES

OPERATION

The Air and Vacuum Valve discharges air at high flow rates during the filling of the system and admits air at high flow rates during the drainage, pump shut-off or at water column separation.

High velocity air will not blow the float shut. Water entry will cause the sealing of the valve.

At any time during system operation, should internal pressure of the system fall below atmospheric pressure, air will enter the system.

The smooth release of air prevents pressure surges and other hydraulic disturbances.

The intake of air in response to negative pressure protects the system from destructive vacuum conditions and prevents damage caused by water column separation. Air entry is essential to efficiently drain the system.

As the system starts to fill, the valve functions according to the following stages:

1. Air in the pipeline is discharged by the valve.
2. The liquid enters the valve, lifting the float and sealing the valve.

When internal pressure falls below atmospheric pressure (negative pressure):

1. The float will immediately drop away from the orifice.
2. Air will enter the system.

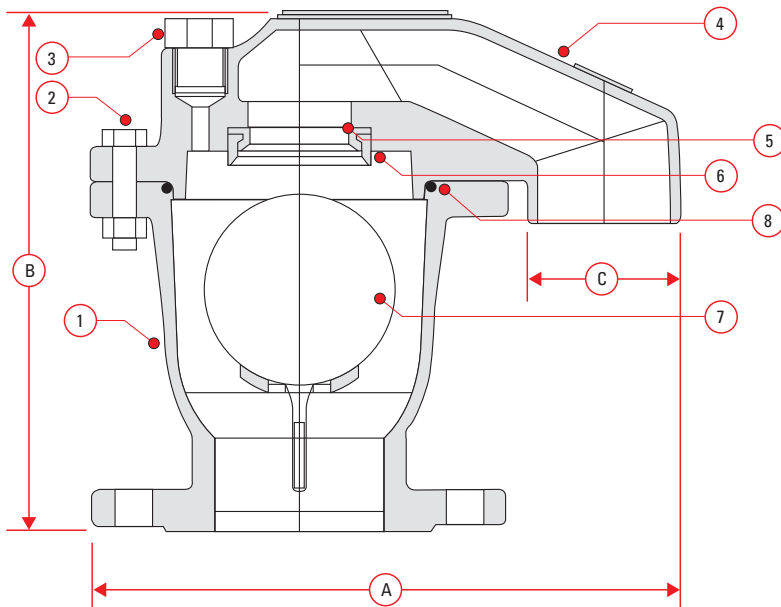

MATERIAL SPECIFICATIONS

NO.	PART	MATERIAL
1	Body	Ductile Iron ASTM A-536 60-40-18* Ductile Iron ASTM A-536 60-40-18* Stainless Steel SAE 316**
2	Bolt and Nut	Stainless Steel SAE 316
3	Plug	Stainless Steel SAE 316
4	Cover	Ductile Iron ASTM A-536 60-40-18* Ductile Iron ASTM A-536 60-40-18* Stainless Steel SAE 316**
5	Orifice Seat	Stainless Steel SAE 316
6	Orifice Seal	E.P.D.M.*, Viton**
7	Float	Stainless Steel SAE 316
8	O-Ring	BUNA-N*, Viton**
-	Basket (2")	Polypropylene

* 65K010, 65K014

** 65K010STST, 65K014STST

MODEL NUMBER AND FLANGE TYPE

MODEL NUMBER	SIZE	CONNECTION	PSI
65K0102T	2"	MNPT	250
65K0102	2"	150 lb. Flg.	250
65K0103	3"	150 lb. Flg.	250
65K0104	4"	150 lb. Flg.	250
65K0106	6"	150 lb. Flg.	250
65K0142	2"	300 lb. Flg.	580
65K0143	3"	300 lb. Flg.	580
65K0144	4"	300 lb. Flg.	580
65K0146	6"	300 lb. Flg.	580
65K0102TSTST	2"	MNPT	275
65K0102STST	2"	150 lb. Flg.	275
65K0103STST	3"	150 lb. Flg.	275
65K0104STST	4"	150 lb. Flg.	275
65K0106STST	6"	150 lb. Flg.	275
65K0142STST	2"	300 lb. Flg.	580
65K0143STST	3"	300 lb. Flg.	580
65K0144STST	4"	300 lb. Flg.	580
65K0146STST	6"	300 lb. Flg.	580

DIMENSIONS AND WEIGHTS

SIZE	DIMENSIONS (IN)				WEIGHT (LBS.)	ORIFICE AREA (IN ²)
	A	B	INT. C	EXT. C		
2" Threaded	6.8	8.9	1.5 BSP	-	18.5	1.23
2" Flanged	6.8	9.9	1.5 BSP	-	25.1	1.23
3"	11.3	10.0	2.5	2.9	39.0	2.8
4"	13.2	10.7	3	3.8	60.0	5.14
6"	21.7	20.9	4.1	5.6	170.0	27.0

K-01 SERIES

K-01 SERIES AIR & VACUUM FLOW RATE

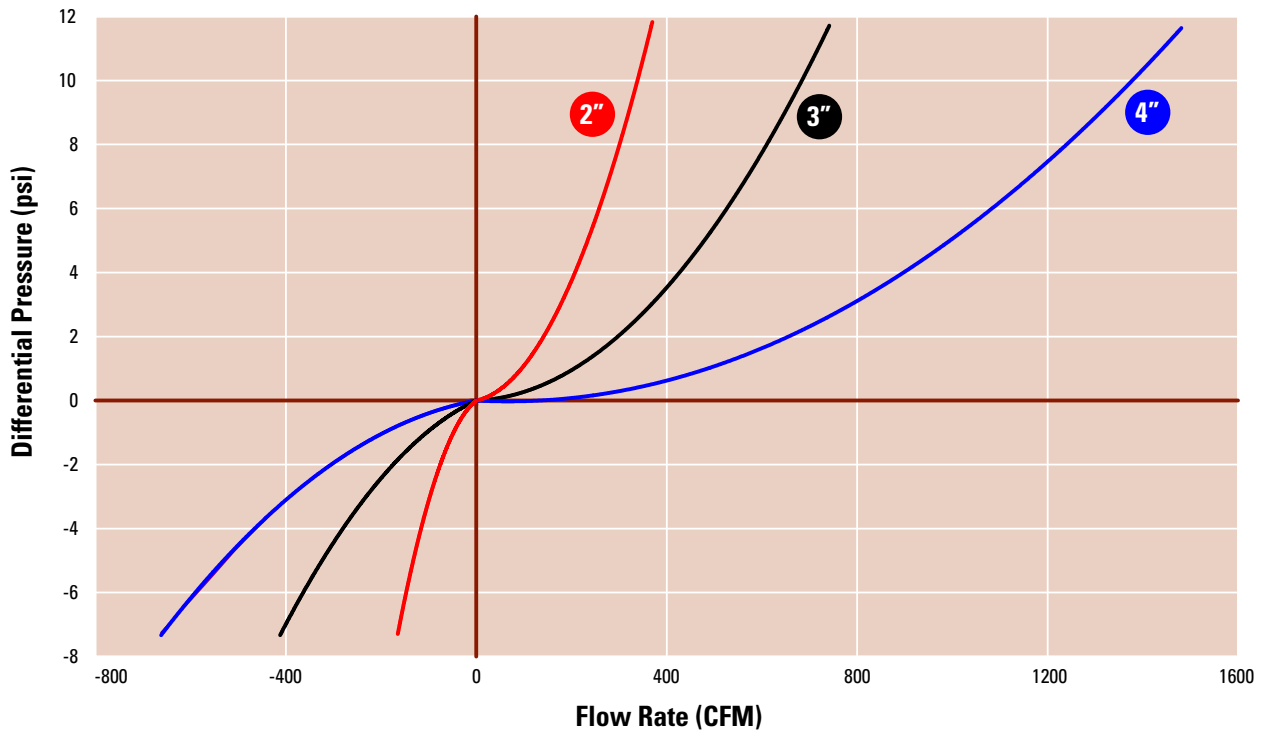

K-01 SERIES AIR & VACUUM FLOW RATE

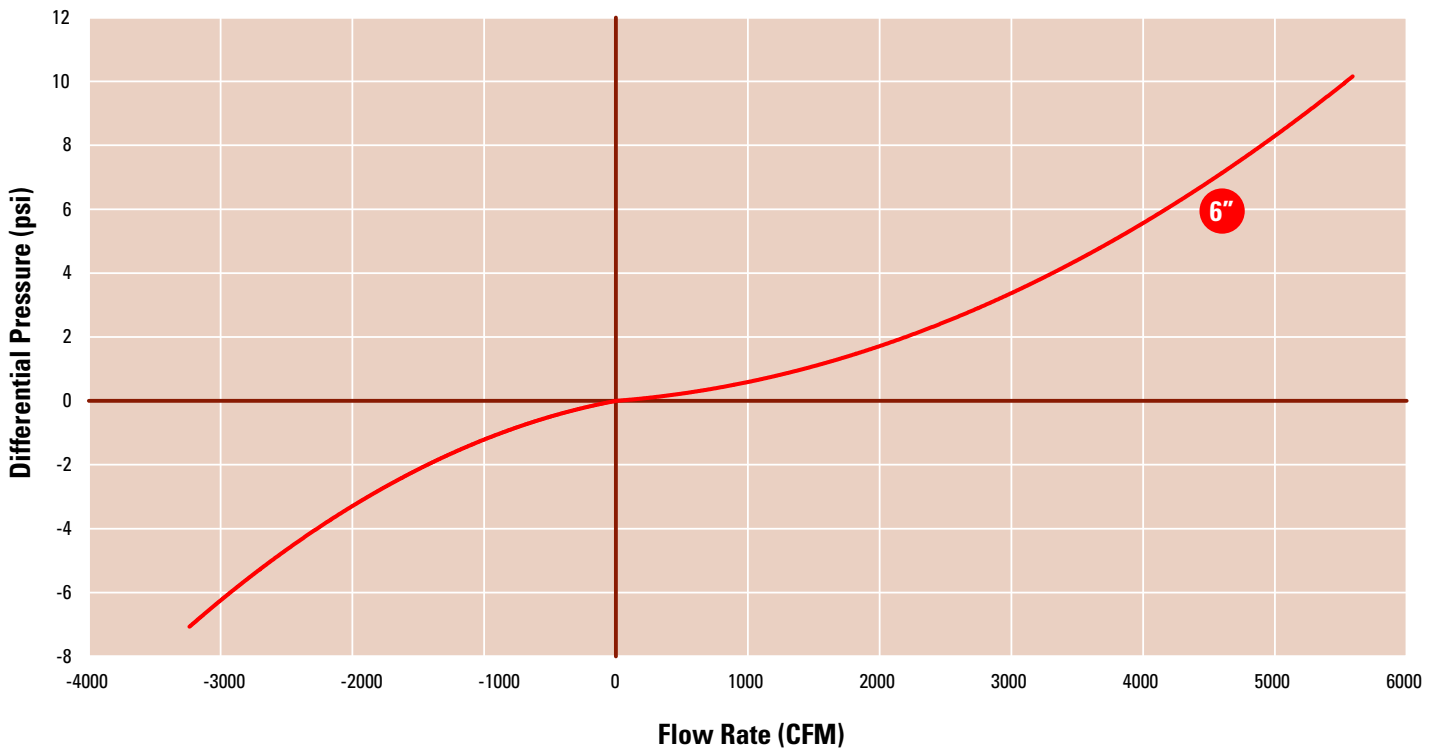

DISCHARGE FLOW RATE (CFM)

SIZE	DIFFERENTIAL PRESSURE (PSI)						
	0	2	4	6	8	10	12
2"	0	140	205	255	297.5	335	368.4
3"	0	334	465	565.5	650	725	792
4"	0	650	886	1,069	1,223	1,360	1,483
6"	0	2290	3,365	4,182	4,900	5,530	6,100

INTAKE FLOW RATE (CFM)

SIZE	DIFFERENTIAL PRESSURE (PSI)						
	-7.5	-6	-5	-4	-3	-2	0
2"	-171	-150.2	-135	-118.2	-99.3	-77	0
3"	-400	-348	-310.3	-269	-223	-169	0
4"	-689	-600	-535	-465	-383	-290	0
6"	-3,280	-2,980	-2,300	-2,300	-1,900	-1,435	0



NETAFIM USA
 5470 E. HOME AVE.
 FRESNO, CA 93727
 CS 888 638 2346
www.netafimusa.com